

NEW DESIGN!
T.H.E. MAMBA™
 can be used as a
 1, 2 or 3 point sling!

FIRST, after removing the T.H.E. MAMBA sling from the package separate it into the three parts shown in the assembly parts list in the top right corner of this page.

Instructions for AMBIDEXTROUS T.H.E. MAMBA™ on M-16

Instructions for fixed buttstock or collapsible weapons

USE THE ASSEMBLY PARTS LIST FOR REFERENCE

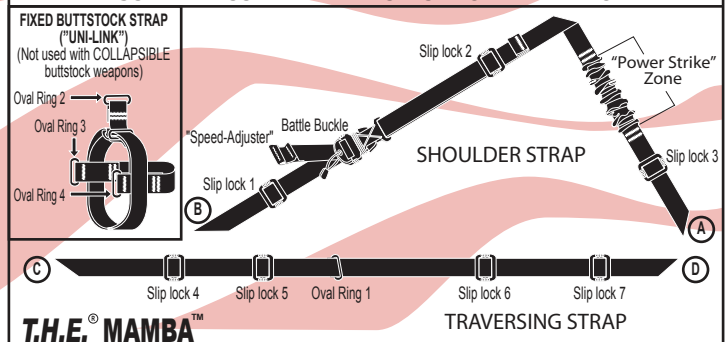

2 POINT SLING INSTRUCTIONS (Uses the SHOULDER STRAP and FIXED BUTTSTOCK STRAP)

<p>1 Mount the FIXED BUTTSTOCK STRAP on the rifle's buttstock.</p>	<p>2 Separate the Straps with Hook & Loop and adjust the FIXED BUTTSTOCK STRAP by pulling from Oval Ring 2.</p>	<p>3 Insert end (A) of the SHOULDER STRAP through Oval Ring 2 on the FIXED BUTTSTOCK STRAP.</p>
<p>4 Thread end (A) of the SHOULDER STRAP back through sliplock buckle 3.</p>	<p>5 Insert end (B) of the SHOULDER STRAP through the front sling mount. Thread end (B) of the SHOULDER STRAP back through sliplock buckle 1.</p>	<p>6 Use sliplock buckle 2 to adjust the size of T.H.E. MAMBA™.</p> <p>FINAL VIEW OF 2 POINT SLING</p> <p>M-16</p> <p>Shotgun</p> <p>T.H.E. MAMBA™ works on most weapons with buttstock and front sling mounts!</p>

3 POINT SLING INSTRUCTIONS (Uses the SHOULDER STRAP, FIXED BUTTSTOCK STRAP, and TRAVERSING STRAP ASSEMBLY)

<p>1 Mount the FIXED BUTTSTOCK STRAP on the rifle's buttstock.</p>	<p>2 Separate the Straps with Hook & Loop and adjust the FIXED BUTTSTOCK STRAP by pulling from Oval Ring 2.</p>	<p>3 Insert end (D) of the TRAVERSING STRAP through Oval Ring 4 of the FIXED BUTTSTOCK STRAP.</p> <p>Use Oval Ring 3 for Left Hand Mounting</p>
<p>4 Insert end (D) of the TRAVERSING STRAP back through sliplock buckle 7.</p>	<p>5 Insert end (A) of the SHOULDER STRAP through Oval Ring 2 on the FIXED BUTTSTOCK STRAP.</p>	<p>6 Thread end (A) of the SHOULDER STRAP back through sliplock buckle 3.</p>
<p>7 Insert end (C) of the TRAVERSING STRAP through the weapons front sling mount. Leave about a hands width between the TRAVERSING STRAP and the weapon.</p> <p>M16 Front Sling Swivel</p>	<p>8 Thread end (C) of the TRAVERSING STRAP back through sliplock buckle 4.</p>	<p>9 Insert end (B) of the SHOULDER STRAP through oval ring 1 on the TRAVERSING STRAP. Thread end (B) of the SHOULDER STRAP back through sliplock buckle 1.</p> <p>FINAL VIEW OF 3 POINT SLING</p> <p>M-16</p>

NEW DESIGN!
T.H.E. MAMBA™
 can be used as a
 1, 2 or 3 point sling!

FIRST, after removing the T.H.E. MAMBA sling from the package separate it into the three parts shown in the assembly parts list in the top right corner of this page.

Instructions for AMBIDEXTROUS T.H.E. MAMBA™ on SHOTGUN
1 POINT SLING INSTRUCTIONS (Uses the SHOULDER STRAP)

Instructions for fixed buttstock or collapsible weapons

USE THE ASSEMBLY PARTS LIST FOR REFERENCE

FIXED BUTTSTOCK STRAP ("UNI-LINK")
 (Not used with COLLAPSIBLE buttstock weapons)

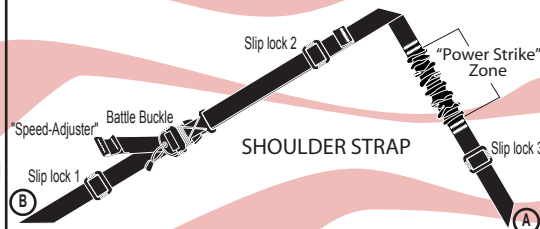
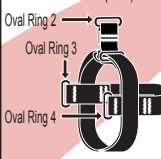

T.H.E. MAMBA™

TRAVERSING STRAP

1 Insert end **(B)** of the SHOULDER STRAP under and around the butt of the shotgun then fold back through sliplock buckle 1. Leave a space between the sliplock buckle and the sling assembly.

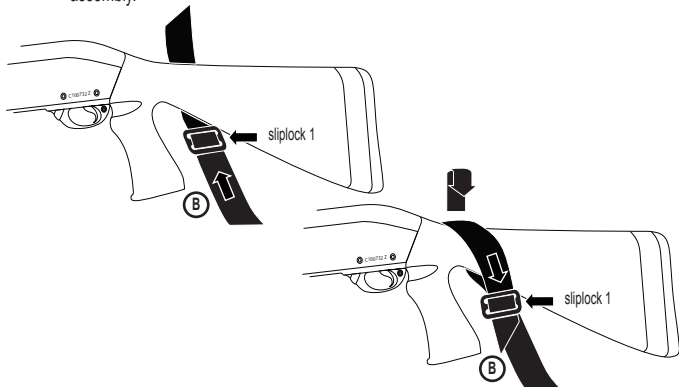

2 Insert end **(A)** of the SHOULDER STRAP through the space created by sliplock buckle 1 then fold back through sliplock buckle 3. Use sliplock buckle 2 to adjust the size of the T.H.E. MAMBA™.

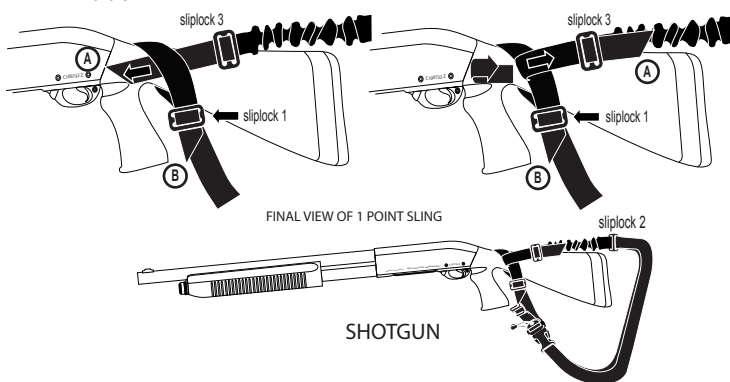

THE FOLLOWING ILLUSTRATES THE FINAL 1, 2, OR 3 POINT SLING ASSEMBLY ON YOUR FIXED OR COLLAPSABLE BUTTSTOCK WEAPON. THE ILLUSTRATIONS FOR AMBIDEXTROUS T.H.E. MAMBA™ ARE FOR VARIOUS WEAPONS. USE THE ASSEMBLY PARTS LIST FOR REFERENCE.

REMINGTON 870

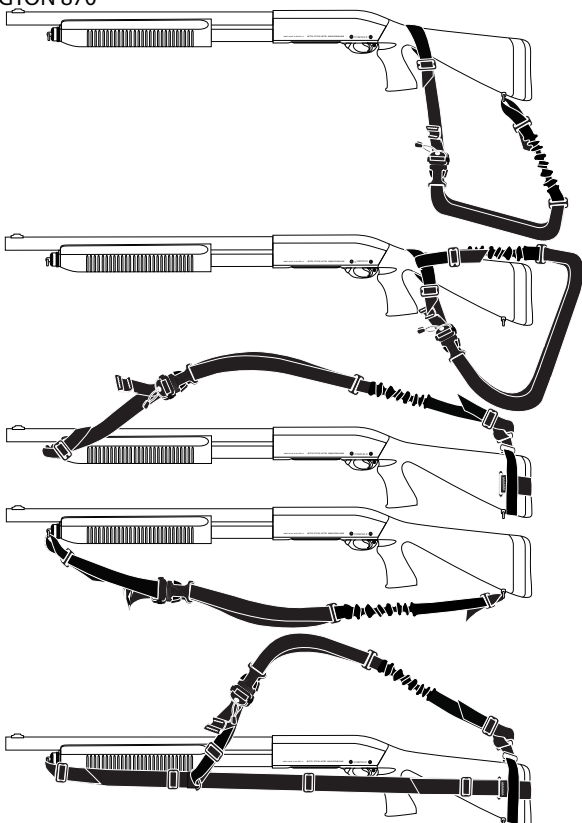

MINI-14® RANCH RIFLE

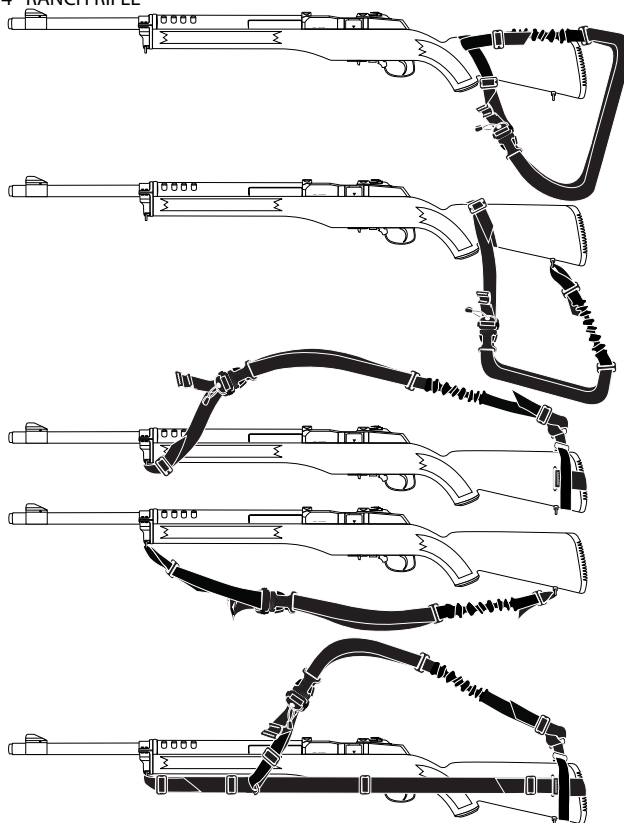

M-16 RIFLE

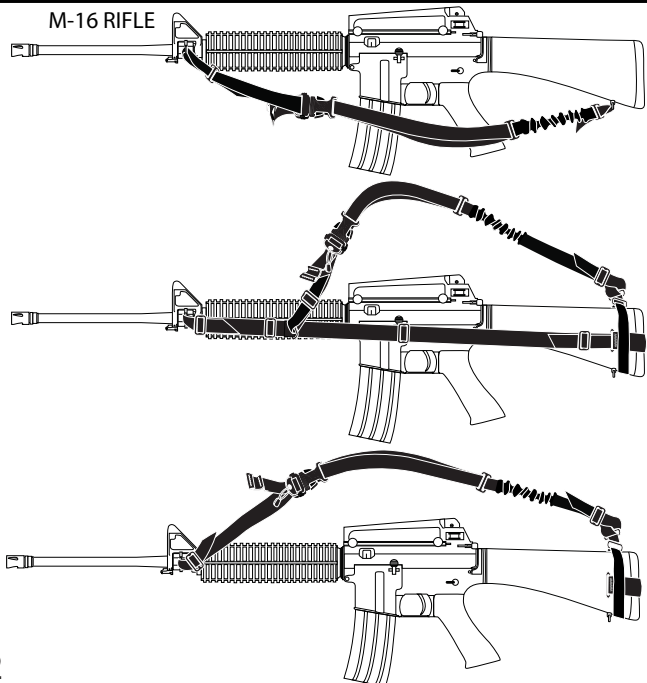

BODY ADJUSTMENT

Body size adjustment can be made by using Slip lock 2 and the "Speed-Adjuster" to tighten or loosen the fit of T.H.E. MAMBA around the wearer.

FIXED BUTTSTOCK STRAP ("UNI-LINK")
 (Not used with COLLAPSIBLE buttstock weapons)

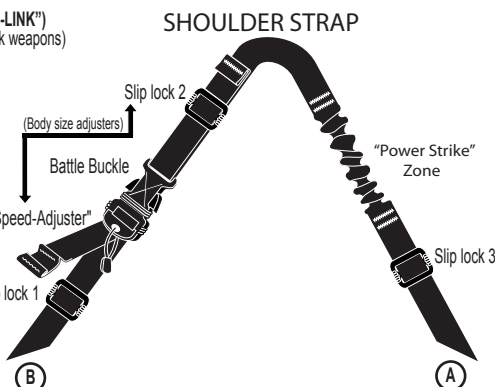
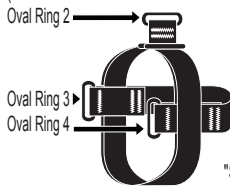

TRAVERSING STRAP

SPEC-OPS ©BRAND
 MADE IN USA Guaranteed for life.

NEW DESIGN!
T.H.E. MAMBA™
 can be used as a
 1, 2 or 3 point sling!

THE FOLLOWING ILLUSTRATES THE FINAL 1, 2, OR 3 POINT SLING ASSEMBLY ON YOUR FIXED OR COLLAPSABLE BUTTSTOCK WEAPON. USE THE ASSEMBLY PARTS LIST FOR REFERENCE.

Illustrations for **AMBIDEXTROUS T.H.E. MAMBA™** on various weapons

Instructions for fixed buttstock or collapsible weapons

USE THE ASSEMBLY PARTS LIST FOR REFERENCE

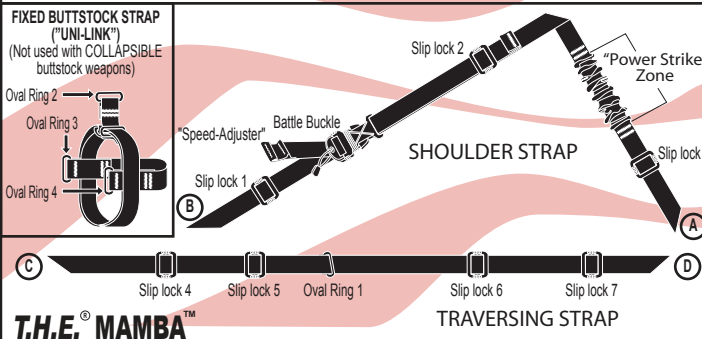

BOLT ACTION RIFLE

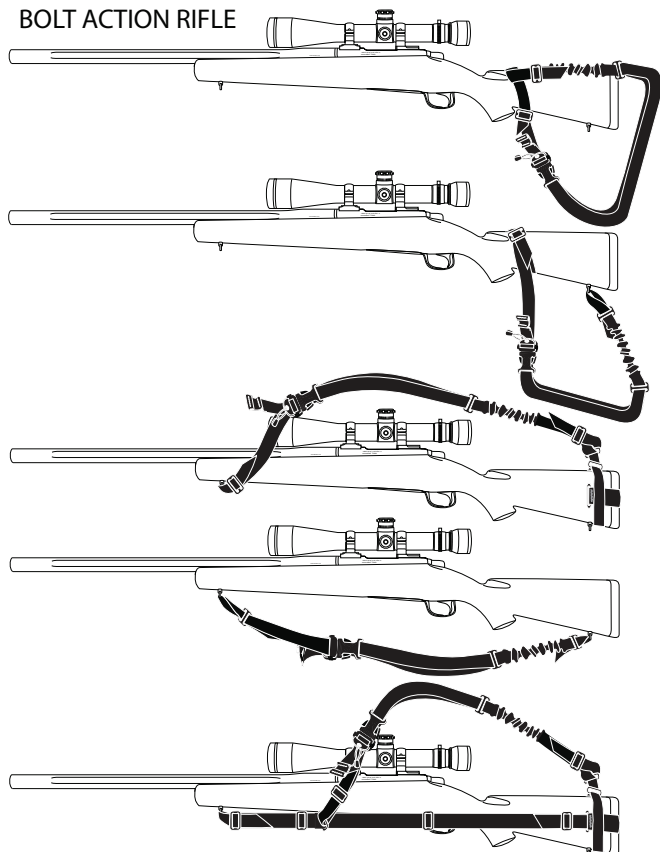

BENELLI M4 SKELETONIZED STOCK

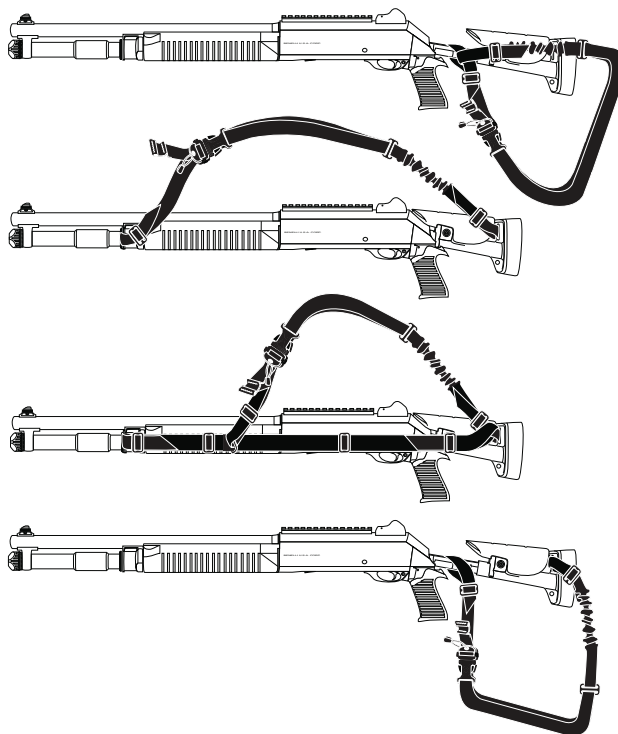

M1A

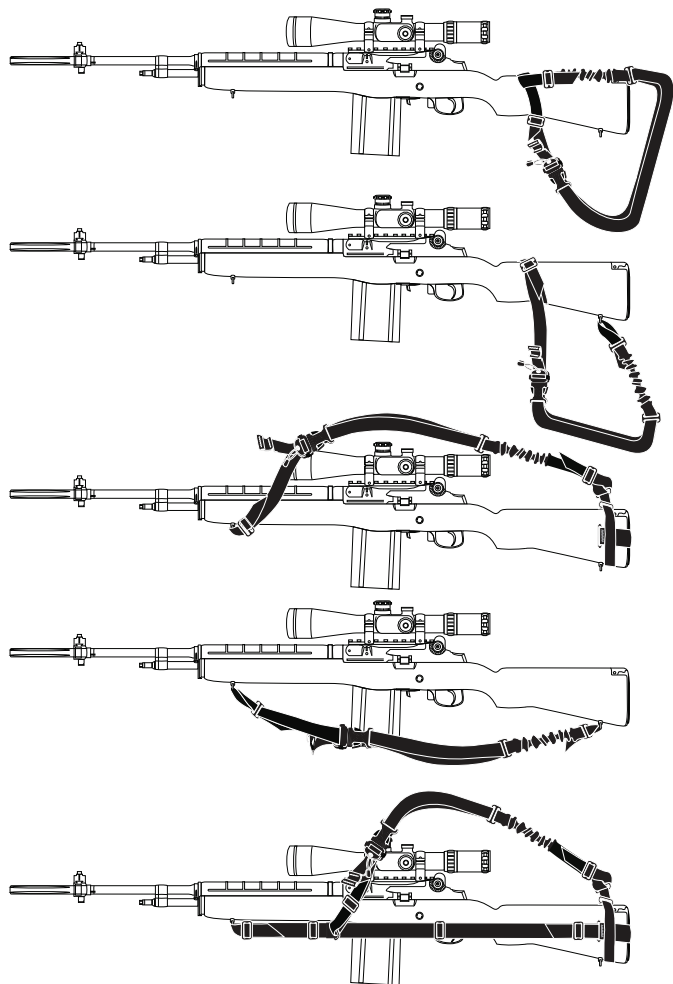

M-4 CARBINE

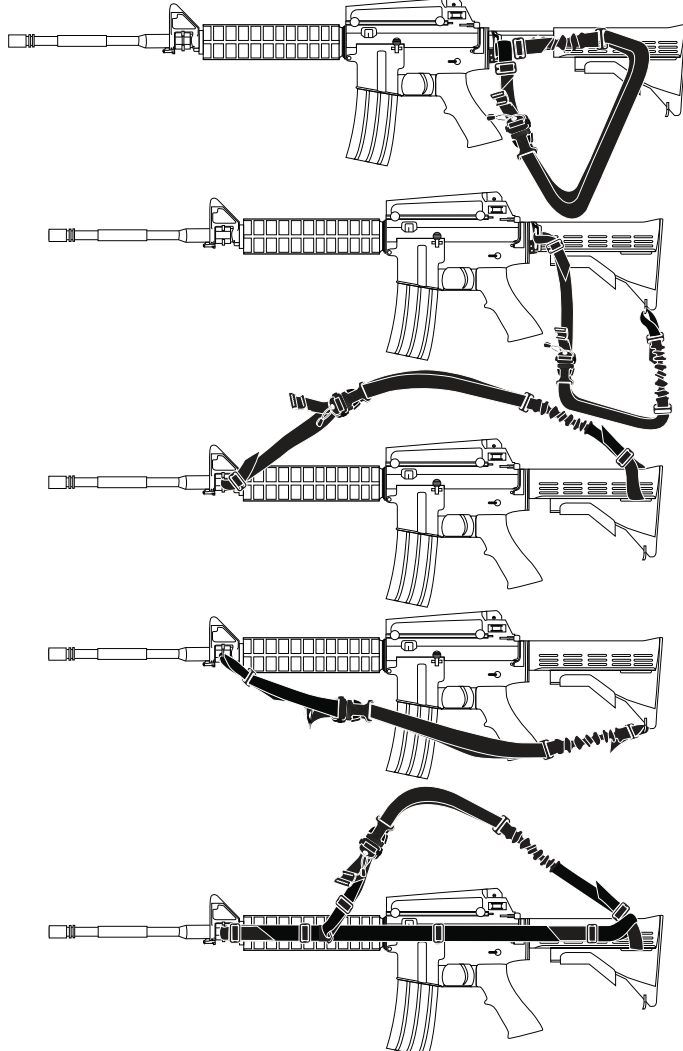

NEW DESIGN!
T.H.E. MAMBA™
 can be used as a
 1, 2 or 3 point sling!

FIRST, after removing the T.H.E. MAMBA sling from the package separate it into the three parts shown in the assembly parts list in the top right corner of this page.
NOTE: FIXED BUTTSTOCK STRAP IS NOT NEEDED FOR COLLAPSIBLE BUTTSTOCK WEAPONS.

Instructions for AMBIDEXTROUS T.H.E. MAMBA™ ON M-4 1 POINT SLING INSTRUCTIONS (Uses the SHOULDER STRAP ONLY)

1 Insert end **(A)** of the SHOULDER STRAP through the sling mount then fold back again through sliplock buckle 3. Leave a space between the sliplock buckle and the sling mount.
 NOTE: Single point sling mount is not included with T.H.E. MAMBA™

2 POINT SLING INSTRUCTIONS (Uses the SHOULDER STRAP ONLY)

1 Insert end **(A)** of the SHOULDER STRAP through rifle buttstock slot.

2 Insert end **(A)** of the SHOULDER STRAP through sliplock buckle 3.

3 Insert end **(B)** of the SHOULDER STRAP through the weapon's front sling mount.

4 Fold back and insert end **(B)** of the SHOULDER STRAP back through sliplock buckle 1. Use sliplock buckle 2 to adjust the size of your T.H.E. MAMBA™

3 POINT SLING INSTRUCTIONS (Uses both SHOULDER STRAP and TRAVERSING STRAP)

1 Insert end **(A)** of the SHOULDER STRAP through the rifle buttstock slot.

2 Insert end **(A)** of the SHOULDER STRAP through sliplock buckle 3.

3 Insert end **(D)** of the TRAVERSING STRAP through the loop created by **(A)** of the SHOULDER STRAP in step 2.

4 Insert **(D)** through sliplock 7.

5 Insert end **(C)** of the TRAVERSING STRAP through the weapon's front sling mount. Fold back and thread end **(C)** through sliplock buckle 4. Leave a hands width between the TRAVERSING STRAP and weapon.

6 Ensure that end **(B)** of the SHOULDER STRAP is connected to oval ring 1 on the TRAVERSING STRAP. Secure end **(B)** by threading it through sliplock buckle 1. Use sliplock buckle 2 to adjust the sling size.

Instructions for fixed buttstock or collapsible weapons USE THE ASSEMBLY PARTS LIST FOR REFERENCE

FIXED BUTTSTOCK STRAP ("UNI-LINK")
 (Not used with COLLAPSIBLE buttstock weapons)

SHOULDER STRAP

TRAVERSING STRAP

T.H.E. MAMBA™

2 Insert end **(B)** of the SHOULDER STRAP through space created by sliplock buckle 3 then fold back through sliplock buckle 1. Use sliplock buckle 2 to adjust the size of the T.H.E. MAMBA™

2 Insert end **(A)** of the SHOULDER STRAP through sliplock buckle 3.

4 Fold back and insert end **(B)** of the SHOULDER STRAP back through sliplock buckle 1. Use sliplock buckle 2 to adjust the size of your T.H.E. MAMBA™

2 Insert end **(A)** of the SHOULDER STRAP through sliplock buckle 3.

4 Insert **(D)** through sliplock 7.

6 Ensure that end **(B)** of the SHOULDER STRAP is connected to oval ring 1 on the TRAVERSING STRAP. Secure end **(B)** by threading it through sliplock buckle 1. Use sliplock buckle 2 to adjust the sling size.