

MULTI-POSITION HOLSTER

SPEC.-OPS. © BRAND

* IMPORTANT *

READ AND FOLLOW THE PROCEDURES PRINTED ON THE BACK OF THIS INSTRUCTION SHEET BEFORE USING OR ADJUSTING THE MP HOLSTER. YOU MUST READ YOUR FIREARM MANUFACTURER'S MANUAL BEFORE USING THIS PRODUCT. FAILURE TO FOLLOW THIS RECOMMENDATION MAY RESULT IN ACCIDENTAL DISCHARGE OF THE FIREARM CAUSING SERIOUS INJURY OR DEATH.

Kydex® "Click-In" internal sleeve holds weapon securely and in position

Fits any belt width up to 4"

Adjustable Thumb Break



Tension Adjuster Screw for a tighter hold on the weapon

Modular capability enables placement of accessories and/or additional equipment

Removable Jump Strap

"Speed-Back" Panel for maximum performance and durability

DO NOT PROCEED until you have completely read and comprehended the content of your firearm's instruction manual and have read, comprehended and complied with the procedures on the **FRONT AND BACK SIDES** of this sheet. **SPEC.-OPS.® Brand WILL NOT BE HELD RESPONSIBLE FOR ANY ACTS OF IGNORANCE, CARELESSNESS, BLATANT STUPIDITY, OR OTHERWISE THAT COULD, MIGHT, OR DO RESULT IN INJURY TO ANY PERSONS, PROPERTY, OR OTHERWISE WHEN USING A FIREARM IN CONJUNCTION WITH THIS HOLSTER.**

ADJUSTING THUMB BREAK

- 1** Remove the two screws holding the Kydex® Liner.

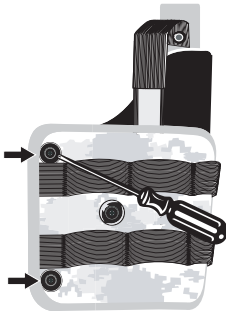

- 2** Adjust both pieces of the thumb break in any direction using the Hook & Loop.

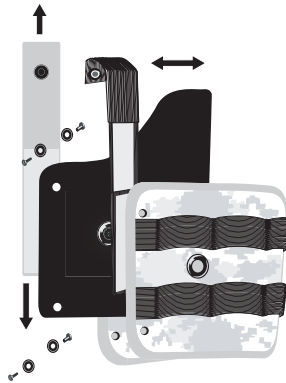

- 3** Assemble the screws and washers back in place. Phillips head screws go on the front and flat head screws on the back of the holster. Use both types of screw drivers to tighten the screws.

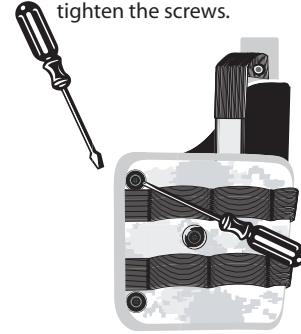

M.O.L.L.E. COMPATIBLE

- 1** Unfasten the snaps on the straps.

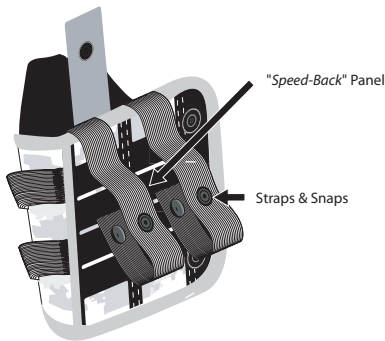

- 2** Loop the straps through the "Speed-Back" panel alternating with the loops on the garment.

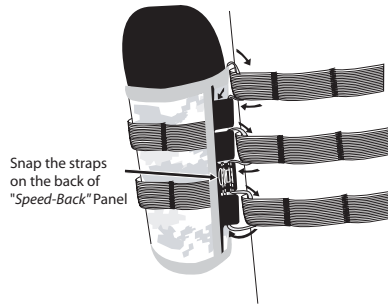

- 3** Mount your MPH in any M.O.L.L.E. compatible garment such as our unique OVER-ARMOR™ Vest.

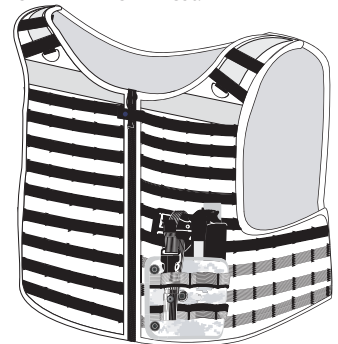

FITS ANY BELT WIDTH UP TO 4"

- 1** Loop both straps through the loops on the "Speed-Back" panel depending on the desired width of the belt.

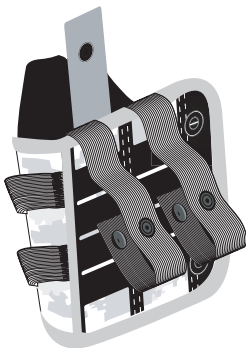

- 2** Use the first row of loops for 1" in width the second row for 2", etc. Up to 4". Loop the straps through the 4th row of webbing and secure with the snaps.

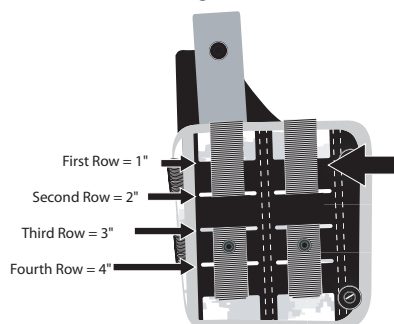

- 3** Feed your belt through the loops created by the straps.

